

KATY SULLIVAN | STAGE MANAGER

katysullivanasm@gmail.com | (580) 402-1922 | katysullivanasm.com

PRODUCTION MATERIALS

DOCUMENTS INCLUDED:

1. Rehearsal/performance calendar, *Shrek Jr.*, Maine State Music Theatre.
2. Daily call, *Junie B. Jones the Musical*, The Little Theatre on the Square
3. Welcome email to cast/guardians, *Junie B. Jones the Musical*, The Little Theatre on the Square
4. Props Tracking, *Clue Onstage*, The Little Theatre on the Square
5. Shift Plot, *Grease*, The University of Central Oklahoma
6. Run Sheet, *We Need a Little Christmas*, The Little Theatre on the Square
7. Run Sheet, *Beauty and the Beast*, Maine State Music Theatre
8. Props preset, *Clue Onstage*, The Little Theatre on the Square
9. Intermission shift, *Grand Ole Country*, The Little Theatre on the Square
10. Calling script pages, *Shrek Jr.*, Maine State Music Theatre
11. Blocking notation, *Shrek Jr.*, Maine State Music Theatre
12. Scene breakdown, *Pinkalicious*, The Little Theatre on the Square
13. Act 1 Entrance/Exit Plot, *Mamma Mia*, The Little Theatre on the Square
14. Rehearsal report, *Shrek Jr.*, Maine State Music Theatre



Rehearsal/Performance Calendar July/August 2021



Monday	Tuesday	Wednesday	Thursday	Friday	Saturday	Sunday
JULY 5	6 Season Auditions (9am – 11am) Rehearsal (2pm – 5pm)	7 Rehearsal (2pm – 5pm)	8 Rehearsal (2pm – 5pm)	9 Rehearsal (10am – 2pm) 5:30p Fellowship Singers ArtWalk	10 Rehearsal (2pm – 5pm) Production Mtg. (5pm)	11 Rehearsal (2pm – 5pm)
12 COMPANY DAY OFF	13 Rehearsal (2pm – 5pm) Fellowship Singers Season Kickoff 6pm	14 Fellowship Singers @ Edie and Dave's 6pm	15 Rehearsal (10am-1pm)	16 Rehearsal (10am-1pm)	17 Rehearsal (10am-1pm)	18 Rehearsal (10am-1pm)
19 COMPANY DAY OFF	20 Rehearsal (10am-1pm)	21 Rehearsal (10am-1pm)	22 Rehearsal (10am-1pm) People Plus Fellowship Singers (1pm)	23 Rehearsal (10am-1pm)	24 Rehearsal (10am-1pm) Production Mtg. (5pm)	25
26 COMPANY DAY OFF	27	28 Rehearsal (10am-5pm)	29	30	31	AUGUST 1
2 COMPANY DAY OFF	3	4 Rehearsal (10am-5pm)	5	6 Welcome Home Tech (10am-5pm)	7 Welcome Home Tech (10am-5pm)	8 Production Mtg. (10am) Welcome Home (7:30pm)
9 Welcome Home (2pm, 7:30pm)	10	11 BATB Tech (10am-10pm)	12 BATB Performances (10am, 1pm, 4pm, 7:30pm)	13	14 Production Mtg. (5pm)	15
16 REHEARSAL 10AM-1:30PM SENSORY 2:30PM-4PM DINNER 4PM-6PM BOARD RUN 6PM-8PM	17 DAY OFF!	18 TECH (10AM-10PM)	19 PERFORMANCE #1-10AM PERFORMANCE #2-1PM PERFORMANCE #3-4PM PERFORMANCE #4-7:30PM	20	21	22

COSTUME FITTINGS (@ costume shop at 14 N. Main St.)

None today!

TIME	SPACE	DESCRIPTION	PERSONNEL
8:40am	Diamond Lounge	Covid Testing	Full Company
8:45am	Diamond Lounge	Into Costume	C. Lynch, A. Agney, S. Camfield, L. Moxley, M. Tribble, E. Tighe
8:50am	Theatre	Into Mics/ Lift & Tumble Call	Full Company
9:00-12:00pm	Theatre	Tech Show	Full Company
12:00-5:00pm Break/ La Cage Aux Folles Matinee			
5:00pm	Theatre	Back into Mic/ Costume	Full Company
5:10- 7:00pm	Theatre	Finish Tech	Full Company
7:15-8:30pm	Theatre	Dress Run	Full Company
8:30pm- END OF REHEARSAL DAY			

Junie B. Jones the Musical Welcome Email to Cast/Guardians

Hi all!

My name is Katy Sullivan, and I'll be the stage manager for Junie B. Jones at LTOTS. I wanted to introduce myself ahead of our first rehearsal on Friday. If you need anything throughout the process, please contact me at this email address, or by phone at 580-402-1922.

I've attached our overall rehearsal schedule. We will be utilizing the theatre's spaces as well as the church (1357 CR, 1200 E, Sullivan, IL 61951) for rehearsals. You'll receive a daily call email detailing the location and specifics of each rehearsal from Chris Benefiel. We will also have copies of the script available if anyone does not have one yet. Rehearsal time is limited so please bring a notebook, pencil, water, and be familiar with the score and script. We will work fast! Please wear closed-toe shoes to all blocking and dance rehearsals.

And finally, passing along a message from our director, Heather, regarding costumes: We are asking for actors (specifically the school kids except Camille and Chenille) to bring items from their own closet to use as costume pieces. For your "school look", think of solid, bright colors or bold patterns (stripes, dots, but please no solid white items, no graphic designs nor items with logos or words. Shorts, dresses, pants or skirts are all fine. Shoes should be comfortable and easy to dance in (no flip flops or sandals, please). Looking forward to meeting you all!--

KATY SULLIVAN | STAGE MANAGER

She/Her/Hers

katysullivan@gmail.com

katysullivan.com

580-402-1922

Prop	Enters	Page	Who	Exits	Page	Who	Notes
Prologue							
Umbrella	USC	7	John	SR	8	Audrey	
TV on cart	Preset OS		SM	SR	Int.	SM	
Glass	Preset OS		SM	SL	Int.	SM	Bar cart
Butcher Knife	SR	7	Audrey	SR	8	Audrey	
Polish rag	Preset OS		SM	SR		Audrey	
Bar cart	Preset OS		SM	N/A	Int.	SM	Struck at intermission
Hors d'oeuvres	Preset OS		SM	N/A	Int.	SM	Struck at intermission
Metal cocktail shaker	Preset OS		SM	N/A	Int.	SM	Struck at intermission
Rocks glasses (x2)	Preset OS		SM	N/A	Int.	SM	Struck at intermission
Champagne flutes (x3)	Preset OS		SM	SL		Heather/Tim	
Champagne bottle	Preset OS		SM	N/A	Int.	SM	Struck at intermission
Wine bottle	Preset OS		SM	N/A	Int.	SM	Struck at intermission
Scene 1							
Mrs. Peacock's purse	USC	11	Glory	SL	Int.	Glory	invitation inside
Box of candy	USC	11	Glory	SL	Int.	SM	Struck to bar cart.
Plum's pipe	USC	13	Chris	SL	Int.	Chris	
Gong	SR	15	Audrey	SR	16	Audrey	
White's purse	SL	12	Heather	SL	Int.	Heather	invitation inside
Scene 2							
Glasses (x7)	SR	16	SM	SR		SM	Struck during scene trans
Table cloth/dressing	SR	16	SM	SR		SM	Struck during scene trans
White tray	SR	16	Audrey	SR	17	Audrey	
Soup bowls (x7)	SR	16	Audrey	SR		SM	Struck during scene trans
Plates	SR	16	SM	SR		SM	Preset on table
Wine bottle	SR	16	SM	SR		SM	Struck during scene trans
Scene 3							
Scarlet's purse	USC	11	Britt	SL	Int.	Britt	
Cigarette case	USC	11	Britt	SL	Int.	Britt	In Scarlet's purse
Cigarette	USC	11	Britt	SL	Int.	Britt	In Scarlet's purse
Flask	USC	11	Glory	SL	Int.	Glory	In Peacock's purse
Confidential envelope	SL	21	SM	SL		SM	Preset on study desk
Invitation letters (x3)	SL	22	Chris, Tim, Lars	SL	Post	Chris, Tim, Lars	
Scarlet's business card	USC	11	Britt	SL	Int.	Chris	In Scarlet's purse, exits in Chris's pocket
Briefcase	SL	29	Craig	SL	34	SM	
Duffel bag	SL	29	Craig	SL	34	SM	Boxes inside
Boxes x6	SL	29	Craig	SL	34	SM	Weapons inside
Candlestick	SL	29	Craig	SL	34	SM	Sturck with study
Wrench	SL	29	Craig	SL	34	SM	Sturck with study
Lead Pipe	SL	29	Craig	SL	34	SM	Sturck with study
Dagger	SL	29	Craig	SL	34	SM	Sturck with study
Revolver (Plum)	SL	29	Craig	SL	34	SM	Sturck with study
Rope	SL	29	Craig	SL	34	SM	Sturck with study
Drink	SL	30	Craig	SL/ bar ct	33	John	Preset on bar cart
Scene 4							

Prop	Enters	Page	Who	Exits	Page	Who	Notes
Scene 5							
Scene 6							
Briefcase	SL	39	SM	SL		SM	Preset on study
Duffle bag	SL	39	Craig	SL		SM	
Briefcase keys	SL	39	Craig	SL		SM	
Latex gloves (pair)	SL	39	Lars	SL	Int	Lars	
Shooter	SL	41	Glory	SI	Int	Glory	
Scene 7							
Scene 8							
INTERMISSION							
Scene 9							
Boddy manor map	SL	50	Tim	SR	50	Tim	
Wrench	SL	51	Evan	SL	51	Evan	
Scene 10							
Plum's pipe	SR	51	Britt	SR	52	Britt	
White's veil	SR	52	Tim	SR	52	Tim	
Scene 11							
Revolver (Plum)	SR	54	EBA	SL	58	EBA	
Rotary phone	SL	53	SM	SL	59	SM	On lounge
Feather Duster	SL	59	EBA	SL	59	EBA	
Pipe headband	SL	59	Craig	SL	59	Craig	
Scene 12							
Noose	SR	62	Craig	SL	62	Craig	
Candlestick	SL	62	Audrey	SL	62	Audrey	
Scene 13							
Candlestick headband	SL	63	Evan	SL	63	Evan	
Scene 14							
Revolver (Plum)	SL		Chris	SL	Post		
Gun	SR		John	SL	Post		
Guns (2)	SL		Lars	SL	Post		



Shift Plot

Updated: 9/23/2019

When (Scene/Song)	Who	What	Move	Where/Spike Color	Notes
Top of Show Preset	Crew	3 Walls (Brick)	Set	CS/ Orange	Wall with pink set CS
End Of 1.1/"Grease is the Word"	Sam B.	SL Wall	Strike	SL	
	Cameron	C Wall	Strike	SL	
	Jackson	SR Wall	Strike	SR	
	Darnell, Logan	Lunch Table	Set	DSL	
End of 1.2/ During Lynch Football Speech	Sarah, Kalyn, Chelsea	Lunch Table	Strike	SL	
	DJ	SL Wall (Lockers)	Set	SL/Yellow	From SR
	Seth	SR Wall (Lockers)	Set	SR/Yellow	From SL
	Ben, Dylan	Bench (from SL)	Set	CS/Yellow	
End of 1.3/ During Vince Ooga Horn Speech	Ben, Dylan	Bench	Strike	SR	
	Josh T.	SR Wall	Strike	SR	
	DJ	SL Wall	Strike	SL	
	Chelsea, Sarah	Marty's Bed	Set	SR/Yellow and Blue	Changed from spacing
	Hailey H.	Bedside Table/Radio	Set	SR/Yellow and Blue	
	Kalyn	Pouf	Set	USC/ Yellow and Blue	
	Morgan	Wall (on Pink)	Set	USR/ Yellow and Blue	From SL. Pink facing DS
End of 1.4/ During Blue Out	Morgan	Wall	Strike	SR	
	Chelsea, Sarah	Marty's Bed	Strike	SL through 3 rd wings	
	Kalyn	Pouf	Strike	SR	
	Hailey H.	Bedside Table	Strike	SR	
During 1.5/ Kenickie's Entrance	Sam C., Josh W., Wyatt, Easton, Darnell, D'Shaud	Car	Set	CS/Green	
End of 1.5 /During "Greased Lightnin' Playoff"	Graeme, Ben, Seth, Dylan, Easton, Sam C.	Car	Strike	SL	
End of 1.5/ During Lynch Cheer Speech	Cameron	Wall	Set	SL/Green and Blue	From SR
	Robby	Wall	Set	SL/Green and Blue	From SL
	Logan V.	Wall	Set	SL/Green and Blue	From SL
End of 1.6/ During Vince Word Bird Speech	Wyatt	Wall	Strike	SL through 2 nd leg	
	Darnell	Wall	Strike	SL through 2 nd leg	
	Josh T.	Wall	Strike	SL through 2 nd leg	
	DJ, Chelsea	Bench	Set	SL/ Green and Yellow	
	Seth	Picnic Blanket	Set	DSR	
INTERMISSION	Crew	Bench/Blanket	Strike	SL	
	Crew	Props	Strike	SL	
	Crew	Marty's Bed	Strike	To shop?	
	Crew	Walls w/Brick	Move	SR	
	Crew	Doody's guitar	Move	SL	
	Crew	37 chairs	Set	Blue spike (DSR leg of chair)	Rows 2,4,6 face US

When (Scene/Song)	Who	What	Move	Where/Spike Color	Notes
During 2.1/ "Shakin' at the Highschool Hop"	Cast	Chairs	Strike	SL	
	Cast	Chairs	Strike	SR	
	Jaci, Cameron, Hayley M., Maya	Table w/ Punch Bowl	Set	USR	
	Sam C., Cara, Easton, Sam B.	Palm Trees	Set	SL	
	Darnell, Erica	SR Chairs	Move	USR/ Yellow and Orange	
	Graeme, Maddi	SL Chairs	Move	USL/ Yellow and Orange	
End of 2.1/ During Blue Out	Jaci, Hayley M.	Table w/ punch bowl	Strike	SR	
	Sam C., Cara, Easton, Sam B.	Palm Trees	Strike	SL	
	Mica, Nicole	SL Chairs	Strike	SL	
	Cameron, McKenna	SR Chairs	Strike	SR	
	Robby	SR Wall	Set	SR/Blue and Orange	From SR
	Logan V.	SL Wall	Set	SL/ Blue and Orange	From SR
	Jackson	Trash Can	Set	SL/Blue and Orange	
	Wyatt, Josh T.	Bench	Set	SR/Blue and Orange	From SL
End of 2.2/ During Blue Out	Graeme	SR Wall	Strike	SR	
	Seth	SL Wall	Strike	SR	
	Jackson	Trash Can	Strike	SL	
	DJ	Bench	Strike	SR	
	Easton, Josh W., Wyatt, Darnell, Sam C.	Car	Set	CS/Green	
End of 2.3 / During Blue Out	Easton, Josh W., Wyatt, Darnell	Car	Strike	SL	
	Graeme, Seth	Bar and stools	Set	DSL/Orange and Green	
	Ben, DJ	Couch and coffee table	Set	USC/Orange and Green	Coffee table preset on couch
	Sarah, Hailey H.	Walls (Brick)	Set	USC/Orange and Green	Behind couch. From SR
	Chelsea, Kalyn	Turntable and Records	Set	DSR	

When (Scene/Song)	Who	What	Move	Where/Spike Color	Notes
End of 2.4/During Blue Out	Kalyn	Turntable and Records	Strike	SR	
	Sarah, Hailey H.	Walls	Strike	SL	
	DJ, Ben	Couch and coffee table	Strike	SL	
	Graeme, Seth	Bar and stools	Strike	SL	
	Sam B., Robby	Table	Set	USR/Pink	2 chairs upside down on table
	Erica, MK	Chairs	Set	USR/Pink	
	Sam C., Logan V.	Table	Set	DSR/Pink	2 chairs upside down on table
	Mica, Maya	Chairs	Set	DSR/Pink	
	Josh W., D'Shaud	Table	Set	DSL/Pink	2 chairs upside down on table
Makenzie, Hayley M.	Chairs	Set	DSL/Pink		

Pg.	Who	Ent/Exit	Loc.	Cue	Action	Notes
PLACES						
	KATY		OS		Jordan, Craig, Maya, Ernesto, Brooke, Lars, Brittany	
ACT ONE						
0. Overture						
1. Opener: Jingle Bells Instrumental						
	BEAGLE	N/A	RV	Cue light/ SM GO	Take main rag OUT	
Scene: Sam is out...						
2. You and Me (But Mostly You)						
	KATY	N/A	L1	During song	Preset Box 3 w/ Box 2 (x2) on top	
Scene: Auditions						
	Nick	R1	DSR	After "attention please.."	Set 2 folding chairs on red spikes	
	Brittany, Craig	L1	DSL	After "attention please.."	Set 2 black stools from LV on red spikes	
	Ernesto, Lars	L1	DSL	After "attention please.."	Set Box 4, and 2x of Box 2 on red spikes	
	BEAGLE	N/A	R1	Nick exits	Handoff 2 chairs legal pad w/music to Nick	
	KATY	N/A	L1	Craig enters	Handoff sheet music to Craig	
	BEAGLE	N/A	R1	Nick exits (again)	Handoff SM clipboard and pencil to Nick	
3A. Chipmunks Roasting						
	KATY	N/A	L1	Lars exits	Handoff sheet music to Lars	
3B. Do You Wanna Build a Snowman?						
3C. Hey Sis, It's Christmas!						
QC SL: Brooke						
3D. Cool Yule						
	KATY	N/A	L1	Brooke completes QC	Handoff sheet music to Brooke	
Scene: Nick Can Sing!						
QC SR: Maya, Brittany, Brooke						
	BEAGLE	N/A	SR	During scene	Prep sleigh	
	KATY	N/A	SL	During scene	Prep Nick's jacket for handoff	
4. Jingle Bells						
	KATY	N/A	L1	Jordan exits	Handoff Nick's jacket to Jordan	Back facing OS
	Lars	L1/L1	L1	Top of song	Strike CS stool w/clipboard	
	KATY	N/A	L1	Lars exits w/stool	Catch stool, strike clipboard	
	Jordan	R1/R1	R1	Top of song	Strike 2 folding chairs	
	BEAGLE	N/A	R1	Jordan exits w/chairs	Catch chairs from Jordan	
	Brooke, Brittany	R1	SR	Nick: "dashing through..."	Push Maya ONS on sleigh to Blue spike	Brittany ONS side, Brooke OFFS side
Scene: Get Motivated						
	Craig, Lars	R1/R1	SR	Therese: You're hired...	Strike sleigh	
	BEAGLE	N/A	R1	Therese: You're hired...	Catch sleigh from Lars and Craig	
	BEAGLE	N/A	R1	After last cue	Prep décor box for Nick to grab	
	KATY	N/A	L1	During scene	Prep ladder for Lars	After Therese exits. Unfolded w/ rungs facing DS

Pg.	Who	Ent/Exit	Loc.	Cue	Action	Notes
5. We Need a Little Christmas						
	Lars	L1/L1	DSC	Jordan: Grab that ladder!	Set ladder DSC from L1	
	Craig	L1/L1	SR	Dance break	Set wreath on SR false pro	
	BEAGLE	N/A	R1	Brittany exits	Handoff wreath to Brittany	
	Brittany	R1/R1	SL	Dance break	Set wreath on SL false pro	
	BEAGLE	N/A	R1	Nick exits	Catch headset, jacket from Nick	
	Jordan, Brittany	L1/L1	L1	Sharae steps off ladder	Strike ladder to L1	
	KATY	N/A	L1	Jordan and Brittany exit	Catch ladder from Jordan and Britt	
	BEAGLE	N/A	R1	Nick exits after song	Catch props from Nick	
Scene: Sad Sharae						
6. Where Are You, Christmas?						
Scene: Enter Marty						
	BEAGLE	N/A	R1	Therese: "Marty, would you mind..."	Handoff giant candy cane to Marty	
	Craig	L1	CS	On entrance	Set mistletoe sprig on USC box	
7. Sleigh Ride/Marshmallow World						
QC SL: Jordan						
	KATY	N/A	L1	After Jordan reenters	Catch candy cane from Jordan as he throws if OFFS	Strike to catch bin
	BEAGLE	N/A	R1	Jordan exits	Catch sparkly vest from Jordan	
Scene: Rehearsal						
QC SL: Brittany						
	KATY	N/A	L1	Brittany exits	Assist with quick change if needed	
	Craig	N/A	SL	Jordan: Where's Monica?	Move Box 3 USC to Green spikes	
	Maya, Ernesto	N/A	SL	Jordan: Where's Monica?	Move Box 2 (x2) USC to Green spikes	
8. Blame It on the Mistletoe						
Scene: Rhinestones						
	BEAGLE	N/A	R1	Marty enters	Handoff giant candy cane to Marty	
9. What Christmas Means to Me (Tap Break)						
Scene: Rehearsal						
	BEAGLE	N/A	R1	Andy: Yes, I'd love...	Handoff music stand to Marty	
10. Hallelujah						
	Craig	N/A	SL	During song	Assemble saxophone under prop shelf	
	Therese	R1	R1	End of song	Strike music stand to R1	
	BEAGLE	N/A	R1	Therese exits	Catch music stand from Therese	
	BEAGLE	N/A	R1	Nick exits after song	Catch candy cane from Nick	
Scene: One More Thing...						
11. Merry Christmas Everyone						
	KATY	N/A	L1	Craig exits	Handoff saxophone to Craig	
	KATY	N/A	L1	Craig exits again	Catch saxophone from Craig	
	BEAGLE	N/A	RV	Cue light/ SM GO	Bring main rag IN	

Pg.	Who	Ent/Exit	Loc.	Cue	Action	Notes
INTERMISSION						
	KATY, BEAGLE	N/A	OS		Intermission shift	See paperwork
PLACES						
	KATY		SL		Lars, Heather, Brooke, Ernesto, Nick	
	BEAGLE		SR		Therese, Maya, Brittany, Craig, Marty, Jordan	
ACT TWO						
12. Entr'acte (Cool Yule)						
Scene: Places!						
13. Kay Thompson's Jingle Bells						
	BEAGLE	N/A	RV	Cue light/ SM GO	Take Main rag OUT	
QC Tappers into Tap Shoes SR and SL :20						
Scene: MC						
QC SL: Brittany, Brooke, Maya 1:15						
	BEAGLE	N/A	R1	During scene	Prep Mic for Nick	
	KATY	N/A	SL/SR	After Jingle Bells	Catch girls' taps from Britt, H/O to Katelynn	
14. Christmas Baby, Please Come Home						
	Maya, Brittany, Brooke	L1	OS	Top of song	Set 3 mics OS on Pink spikes	
	Nick	R1	DSR	Top of song	Set Mic OS on Pink spikes	
Scene: MC						
	Maya, Brittany, Brooke	R1	R1	End of song	Strike 3 Mics	
	Nick	L1	L1	End of song	Strike 1 mic	
	KATY	N/A	L1	Nick exits	Catch Mic from Nick	Strike to green room
	BEAGLE	N/A	R1	Girls exit	Catch mics from girls	
	BEAGLE	N/A	FOH	After last cue	TO HOUSE FOR VIDEO	
15. What Christmas Means to Me						
QC SR: Brittany, Maya, Brooke						
	KATY	N/A	L1	During song	Preset piano for Marty	Keys facing US. Applause sign on top, Low A Bell at C
	KATY	N/A	L1	Lars exits	Catch props from Lars	
	KATY	N/A	L1	After setting piano	TURN PIANO ON	x -> SR for next cue
	KATY	N/A	R1	Ensemble exits	Catch gift boxes	
Scene: MC						
	Marty	L1/L1	CS	Therese MC speech	Push piano on from L1	
16. One Piano/ Four Players Christmas Medley						
	KATY	N/A	L1	During song	Prep piano bench for Lars	
	Brooke, Brittany	R1/L1	CS	During song	Rotate piano DS	
	KATY	N/A	L1	During song	Prep Box 4 w/ punch bowl and cups preset	Set Box 3 DS of 4 T02 position, move Box 4 to wing
	KATY	N/A	L1	Brooke exits	Catch Applause sign and bell	
17. O Holy Night						
	Lars	L1	CS	Top of song	Set piano pedal and bench	
	BEAGLE	R1	L1	Blackout end of song	Strike piano and bench to L1	
	KATY	L2/L2	L2	Blackout end of song	Page drape for piano	From OS side of drape
	Nick	L1	CS	Blackout end of song	Set box 4 CS just OS of green spike	Green spikes from 1.8
Scene: Backstage						
	KATY	N/A	L2	Once piano is struck	Make sure piano is turned off	

Pg.	Who	Ent/Exit	Loc.	Cue	Action	Notes
18. Who Spiked the Eggnog?						
	KATY	N/A	L1	During scene	Preset changing screen against false pro	
	KATY, BEAGLE	N/A	SR	During song	Move Box 4 from sleigh to preset OFFS of escape stairs	
	Nick, Lars	OS/L1	CS	Transition after song	Strike Box 4 to L1	
Scene: No Voice						
QC Maya and Brooke OS						
	Ernesto, Craig	L1/L1	SL	Transition after song	Set changing screen DSL on Orange spikes	
	BEAGLE	N/A	SR	During scene	Prep rolling chair in L1 for Brooke	
	KATY	N/A	L1	Boys exit	Catch changing screen and strike	
19. Santa Tell Me						
	Brooke	R1	OS	Transition after scene	Set rolling chair OS	
	Katy	N/A	l1	Top of song	Preset box 3	
	KATY	N/A	L1	Brooke exits	Catch rolling chair from Brooke, H/O Lars' scarf and jacket	Strike chair to hallway
	BEAGLE	N/A	R1	TBD	Push on mailbox on stick	
Scene: Red Dress						
	KATY	L1/L1	CS	End of Santa Tell...	Set Box 3, and move Boxes 1/2 to cluster	Orange/glow spikes USC for box 3. See position ppw
	BEAGLE	R1/R1	SR	End of Santa Tell...	Strike Boxes 1 and 2 from SR	
20. Wrapped in Red						
	BEAGLE	N/A	R1	During song	Preset Boxes 1,2,3	
Scene: Marty Speaks!						
	BEAGLE	R1/R1	SR	Top of scene	Set boxes 1,2,3 at cluster. Glow spikes	See box position ppw
	KATY	L1/L1	SL	Top of scene	Move boxes 1,2,3 to cluster. Glow spikes	See box position ppw
21. You Make It Feel Like Christmas						
	BEAGLE, KATY	N/A	R/L	During song	Preset box 4	
Scene: MC						
QC SL: Everyone but Brittany and Ernesto						
QC SR: Brittany and Ernesto						
	BEAGLE	R1/R1	CS	Applause	Set Box 4, move Boxes 1.2.3 in position. Glow spike USC	See box position ppw
	KATY	L1/L1	CS	Applause	Set Box 4, move Boxes 1.2.3 in position. Glow spike USC	See box position ppw
22. All I Want for Christmas is You						
	KATY	N/A	L1	After last cue.	Help Katelynn zip Sharae's dress	
	KATY	N/A	L1	Sharae enters	Handoff small gift to Sharae	
	BEAGLE	N/A	RV	Lars throws gift OFFS	Catch gift from Lars	
23. Exit Music						
	BEAGLE	N/A	RV	Cue light/SM Go	Main rag IN	
POSTSHOW						
	KATY, BEAGLE	N/A			Repack for next show	

Pg	Who	Ent/Exit	Loc.	Cue	Action	Notes
PLACES						
	KATY		SR		Rebecca, Matthew, Kevin, John P., Caroline, Johnny R.	
	KYLE		SL		Morgan, Natalie/Maggie, Mikayla	
	KYLE		HOUSE		Lizzie/Sophia	
	RAIL CREW		SL		CONNOR	
	CREW SR		SR		KATY	
	CREW SL		SL		CASSIE, LISSY, KYLE	
	KELSIE		L1	Morgan in place	Handoff Mic for CS	
	KYLE		L1	SM Go	Cue for Morgan ent	
	KELSIE		L1	Morgan exits	Open door for exit and catch mic from Morgan	
Music Cue #1 - Once Upon a Time						
SCENE 1: ONSTAGE						
	LISSY	N/A	L1	"She revealed herself..."	Pull Mikayla's cloak off with tieline	Strike onto prop costume rack
Music Cue #2: Imagination						
8	KATY	N/A	R2	Actors' exit	Page drape	
8	*QC* Rebecca, Matthew, Caroline, Johnny Ext: R1 Disney Costumes to Main Costumes Ent: SR Time 2:00					
9	KYLE	N/A	L2	PURPLE QLT	Page drape for rack	
9	CASSIE, LISSY	L2/R2		PURPLE QLT	Push costume rack across stage	
9	KATY	N/A	R2	PURPLE QLT	Page drape for costume rack	
9	KATY	N/A	R1	Costume rack off	Strike costume rack to lift	
9	CASSIE, LISSY	R1/R1	SR		Preset table in 1st Leg	
SCENE 2: ROSE'S COTTAGE						
10	EMMA	N/A	R2	On Rose's exit	Page drape	
10	*QC* Natalie/Maggie Ext: R1 Terry to Rose Main Ent: R1 Time 0:56					
10	KATY	N/A	R1	Transition light/actors ent	Page drape for table	
10	LISSY, CASSIE	R1/L1,R1	CS	Transition light/actors ent	Set table w/props and 1 chair on GREEN SPIKES	Hand mirror and mudmask jar
10	Rebecca	R1		Transition light/actors ent	Flip CS chair on table, move jar to SL chair	
10	Matthew	N/A	L1	Transition light/actors ent	Page drape for KYLE	
10	KYLE	L1/ R2	CS	Transition light/actors ent	Set 1 chair SR side of table, 1 chair SL side of table	
10	KATY	N/A	R2	Rose QC complete	Handoff broom to Rose	

Pg	Who	Ent/Exit	Loc.	Cue	Action	Notes
Music Cue #3- Waiting, Wondering, Wanting, Wishing						
Music Cue #4- Studley						
21	CASSIE	HR/HR	CS	"Would anyone in the audience..."	Pickup hand mic SR, bring Lizzie/Sophie OS	
SCENE 3: THE CLIFFS AND THE CASTLE DOOR						
23	KATY	N/A		R2	Page drape for Rebecca	
23	KATY	N/A	R1	PURPLE QLT	Page drape for LISSY & CASSIE	
23	LISSY, CASSIE	R1/R1	CS	PURPLE QLT	Strike table w/1 chair & props	
23	Rebecca	R2	SR	PURPLE QLT	Strike chair	
CONTINUED SCENE 3: THE CLIFFS AND THE CASTLE DOOR						
23	KYLE	N/A	L3	PURPLE QLT	Page drape for Caroline	
23	Caroline	L1	SL	PURPLE QLT	Strike chair	
23	Johnny R.	SL	USCL	PURPLE QLT	Set ladder on YELLOW spikes	from preset behind column
24	KATY	N/A	SR	Once table is off	strike mirror, jar and letter from table to props shelf	
Music Cue #5- Rules Intro						
Music Cue #6- Rules of the House						
	KATY, CASSIE	N/A	R2	During Song	Preset Trellis 1 & 2	
SCENE 4: THE CASTLE GARDEN						
	KATY, KYLE		R/L		Spot moon IN	
28	RQ #1: MOON (Lineset 24) IN			RED QLT	CONNOR	
28	KATY	N/A	R3	On Matthew's ext	Catch cape	Handoff to Gabs
28	Johnny R.	USC	USC	GREEN QLT	Strike Ladder	back to preset behind column
28	Matthew	N/A	R1		Page drape for trellis	
28	LISSY	R2/R2	SR	GREEN QLT	Set trellis 1 on ORANGE spikes	
28	CASSIE	R2/R2	SR	GREEN QLT	Set trellis 2 on ORANGE spikes	
28	Kevin, Lathan	L2/L2	USCL	GREEN QLT	Set bench on ORANGE spikes	
28	Lathan	L2	SL	On exit	Close drape on exit	
Music Cue #7- In the Garden						
	LISSY, CASSIE	N/A	L1	During Song	Preset table	
SCENE 5: ROSE'S COTTAGE						
	KATY, KYLE				Spot Moon OUT	
32	RQ #2 MOON OUT			BLUE QLT	CONNOR	
32	Matthew	N/A	R1	PURPLE QLT	Page drape for trellis	
32	Johnny R.	R2/R2	SR	PURPLE QLT	Strike Trellis 1	
32	Lathan	R2/R2	SR	PURPLE QLT	Strike Trellis 2	
32	LISSY, CASSIE	R1/L2	CS	PURPLE QLT	Set table on GREEN spikes	Strike bench after setting table

Pg	Who	Ent/Exit	Loc.	Cue	Action	Notes
CONTINUED- SCENE 5: ROSE'S COTTAGE						
32	LISSY, CASSIE	R2/L2	SL	PURPLE QLT	Strike bench	
32	Caroline	L1	CS	PURPLE QLT	Set 2 chairs	
32	Rebecca	R2	CS	PURPLE QLT	Set 1 chair	
32	GABS	N/A	R2	Rebecca's ext	Close drape	
32	KYLE	N/A	L2	CASSIE/LISSY exit	Close drape	
32	KATY, Lathan	N/A	R2	Trellis offstage	Strike trellis 1&2 to alcove, preset throne in R2	
Music Cue #8- Rules of the House Reprise						
38	KATY	R1	SR	Top of song/ light change	Page drape for table & chair	
38	LISSY, KYLE	R1, L1/R1	SR	Top of song/ light change	Strike table	LISSY ent R1, KYLE ent L1
38	Caroline, Matthew	L1	SL	Top of song/ light change	Strike 2 chairs	
38	Rebecca	R1	SR	Top of song/ light change	Strike chair	
38	Lathan, CASSIE	R2/R2,L2	CS	Once table clear	Set throne	CASSIE exit R1, Lathan ext L1
SCENE 6: THE CASTLE						
SCENE 7: ROSE'S COTTAGE						
41	Lathan, KYLE	L2/R2	SR	PURPLE QLT	Strike Throne, close drape on exit	
41	Matthew, Caroline	L1	CS	PURPLE QLT	Set chair	Matthew set chair CS, Caroline SL side of table
41	KATY	R1	SR	PURPLE QLT	Page drape for table & chair	
41	Rebecca	R1	CS	PURPLE QLT	Set chair	Set chair SR side of table
41	LISSY, CASSIE	R1/R1	CS	Once throne clear	Set table ON GREEN spikes	
41	KATY, CASSIE	N/A	R1	Once shift done	Preset trellis 1 & 2	
SCENE 8: CASTLE GARDEN						
43	KYLE, CASSIE	R2,L2/R2	SR	PURPLE QLT	Strike table	KYLE ent L2, CASSIE ent R2.
43	Matthew, Caroline	L1	SL	PURPLE QLT	Strike chair	
43	Rebecca	R2	SR	PURPLE QLT	Strike chair	
43	KATY	R2/R2	SR	PURPLE QLT	Set Trellis 2	Close drape on exit
43	LISSY	R2/R2	SR	PURPLE QLT	Set Trellis 1	
43	Kevin, Lathan	L2	SL	PURPLE QLT	Set bench	
43	Lathan	L2	L2	On exit	Close drape	
Music Cue #9- In the Garden Reprise						
Music Cue #10- The Dream						
45	LISSY	N/A	R3	Mikayla's ent	Page drape	
46	LISSY	N/A	R3	Mikayla's exit	Page drape	

Pg	Who	Ent/Exit	Loc.	Cue	Action	Notes
SCENE 9: EXTERIOR OF THE CASTLE						
47	Johnny R.	N/A	USC	Rose exits	Set ladder	from preset US of column
47	GABS	N/A	R1	PURPLE QLT	Page drape for trellis	
47	KATY	R2/R2	SR	PURPLE QLT	Strike Trellis 2	
47	LISSY	R2/R2	SR	PURPLE QLT	Strike Trellis 1	
47	John P.	N/A	L2	PURPLE QLT	Page drape for bench	
47	CASSIE, KYLE	L2/L2	SL	PURPLE QLT	Strike Bench	
Music Cue #11 When She Looks at Me (Dream Waltz)						
	KATY	N/A	R2	On Dream Rose ent	Page drape	
Music Cue #12 Imagination Reprise						
54	LISSY, CASSIE	N/A	R1	On song	Preset table	
54	Matthew	N/A	USCL	On song	Strike Ladder	to preset US of column
54	*QC* Natalie/Maggie Ext:SR From Main to Red Ball Gown Ent: SR Time 2:10					
54	*QC* Kevin Ext: L1 From Main to Waltz Look Ent: L3 Time 2:10					
Music Cue #12A Waltz						
	KATY, CASSIE	N/A	R2	On music	Page drape for Rose ent/ Maxwell exit	
	KYLE	N/A	L1	On exit	Page drape for Rose	
SCENE 10: ROSE'S COTTAGE						
57	KATY	N/A	R1	GREEN QLT	Page drape	
57	Rebecca	R1	CS	GREEN QLT	Set chair	
57	Matthew, Caroline	L1	CS	GREEN QLT	Set chair	
57	LISSY, CASSIE	R1/L1		GREEN QLT	Set table on GREEN spikes	
57	KATY	N/A	R2	Scene change complete	Preset trellis 1 & 2	
61	KATY	N/A	R1		Page drape for Lissy, Cassie, and John's exit	
61	LISSY, CASSIE	L1/R1		All: "1...2...3..."	Drag John P. off SR	
SCENE 11: CASTLE GARDEN						
	KATY, KYLE		R/L	PURPLE QLT	Spot Moon IN	
62	RQ #3: Moon In			RED QLT	CONNOR	
62	Caroline, Rebecca, Matthew	R2		PURPLE QLT	Strike 3 chairs, Close drape on exit	
62	CASSIE, John P.	R1/R1		PURPLE QLT	Strike Table	
62	LISSY	R1/R1		PURPLE QLT	Set Trellis 1	
62	Johnny R.	R1/R1		PURPLE QLT	Set Trellis 2	Close drape on exit
62	Lathan, Kevin	L3		PURPLE QLT	Set Bench	
	QC Lizzie/Sophia Ext: R1 From Main into Angel Ent: R2 Time 1:20					
Music Cue #13- Too Soon to Say Goodbye						
Music Cue #14- I Believe in Magic						
	CASSIE	N/A	R2	On music	Pg drape for Cindy's ent	
Music Cue #15- Bows						



Beauty and the Beast

Run Sheet

Updated: 8/12/21

Pg	Who	Ent/Exit	Loc.	Cue	Action	Notes
POST SHOW						
	LISSY, KYLE			House Clear	Sweep Confetti	
	KATY				Return Valuables	
	CASSIE/KATY				Prop check in	
	All				Meet SR for notes	

STAGE LEFT- Prop Shelf	
Scarlet's purse	
<ul style="list-style-type: none"> • Cigarette in case 	
<ul style="list-style-type: none"> • Invitation letter 	
<ul style="list-style-type: none"> • Business card 	
Mrs. White's purse	
<ul style="list-style-type: none"> • Invitation letter 	
Wadsworth's Umbrella	
Plum's red pipe	
Invitation Letter	
Peacock's Box of candy	
Briefcase key	
Wadsworth's key ring	
Yvette's feather duster	
Boddy Manor map	
Candlestick on headband	
Plastic Candlestick	
Pipe on headband	
Wadsworth's gun	
Green's gun	
Scarlet's Payroll	
Loveletter to Plum	
Negatives	
Notarized record	
Vial	
Gloves (pair)	
Wine bottle	
Boddy's briefcase (#s on 0)	
Duffle bag w/ 6 velvet bags	
<ul style="list-style-type: none"> • Candlestick (red bag) 	
<ul style="list-style-type: none"> • Wrench (yellow bag) 	
<ul style="list-style-type: none"> • Lead Pipe (green bag) 	
<ul style="list-style-type: none"> • Dagger (blue bag) 	
<ul style="list-style-type: none"> • Revolver (purple bag) 	
<ul style="list-style-type: none"> • Noose (white bag) 	

STAGE LEFT- Ladies' Dressing Rm	
Mrs. Peacock's purse	
<ul style="list-style-type: none"> • Flask 	
<ul style="list-style-type: none"> • Invitation Letter 	
Shooter bottle	

STAGE LEFT- Men's Dressing Rm	
Silver zippo lighter	
Skeleton key	
Invitation letters (x2)	

STAGE LEFT- Deck	
Green leather armchair (GR)	
Small table w/ rotary phone	

USL POD- Study/Library	
Desk	
<ul style="list-style-type: none"> • Confidential envelope 	
Settee	
Collapsible Table	
Curtain on bookcase	

DSL POD- Lounge	
Stripey arm chair	

STAGE RIGHT- Prop Shelf	
Cook's Butcher knife	
Cook's Gong and mallet	
White tray	
<ul style="list-style-type: none"> • Soup bowls (x6) 	
Silver tray w/ 6 glasses	
Basket of rolls	
Stabby dagger with magnet	
Tiny notebooks w/ golf pencils (x2)	
Noose	
Lemon plant for conservatory	
Ramp for wagons	

STAGE RIGHT- Deck	
Poker Dogs painting	
Billiard tabletop	
3 chairs	

USR POD- Kitchen/Conservatory	
Fridge	
Giant pot and utensil jar	
Conservatory plants (x2)	

DSR POD- Dining/Billiard Room	
2 Dining tables (w/ false tops w/ plates)	
<ul style="list-style-type: none"> • 6 detachable spoons 	
2 benches	
Last Supper painting on wall	

Onstage	
Bart Cart DSL on Grey Spikes	
<ul style="list-style-type: none"> • Hors d'oeuvres tray 	
<ul style="list-style-type: none"> • Silver shaker 	
<ul style="list-style-type: none"> • Rocks glasses (x4) 	
<ul style="list-style-type: none"> • White napkin 	
<ul style="list-style-type: none"> • Champagne flutes (x2) 	
<ul style="list-style-type: none"> • Champagne bottle 	
TV on cart DSR on blue spikes	



SL Bar Cart Preset



USL Study Pod Preset



USR Kitchen Pod Preset



DSR Dining Room Preset

ONSTAGE	
Strike Act 1 Props (with exception of shaker/bottles/rags at bar)	
Set Opry circle on red spikes DSC	
Set red tablecloth, 1 centerpiece jar and 1 drink menu on DSR table	
Set 1 mic stand at tall spike w/ Tyler's (white white) handheld on bandstand OS of Elleon's spot	
Set 2 mason jars on SR barrel by piano	
Set 1 mason jar on SR proscenium thingy	
Set 1 mason jar on SL side of drum platform	

ONSTAGE BAR	
Set tray with 3 shot glasses under	
Set 1 beer bottle	
Set Elleon's drink	
Set Empty tambourine crate on bottom DS shelf	
Set 2 menus and 1 mason jar/3 tea lights	



Act 2 Bar Set Up

STAGE RIGHT	
Set 2 mic stands on short spike in Wing 1	
Set John's (blue blue) handheld mic on storage stand	
FLIP SIGN ON SR VOM DOOR TO "OPEN" FACING OS	

STAGE LEFT	
Strike Act 1 poster/Set act 2 "Live Band Tonight" poster on barrel	

FIONA

You're... an ogre?

SHREK

Oh, you were expecting Prince Charming?

FIONA

Well... yes actually. Oh, no! I'm supposed to be rescued by my true love! Not by some ogre and his... pet.

DONKEY

Well, so much for noble steed.

FIONA

You're not supposed to be an ogre.

SHREK

Princess, I was sent to rescue you by Lord Farquaad, okay? He's the one who wants to marry you.

FIONA

Oh. Then why didn't he come rescue me?

SHREK

Good question. You should ask him that when we get there tomorrow.

FIONA

Tomorrow? Oh my gosh, it's almost sunset!

SHREK

So?

FIONA

I didn't realize it was so late. We need to make camp.

SHREK

Camp? But you've just escaped!

FIONA

Yes, and I found the whole ordeal quite exhausting. I need to rest immediately.

SHREK

That's unfortunate, because we're gonna keep going.

FIONA

I NEED TO FIND SOMEWHERE TO CAMP RIGHT NOW!

ON THE RAIL: SBY
CUE 24 ON RED +
CUE 26 ON BLUE

SHREK

Very well. There's a cave right there. SBY | LX 223-231 + OGRE LX

DONKEY

Shrek! That's no place for a princess.

FIONA

No, no it's perfect. Well gentlemen, I bid thee good night!

DONKEY

You want me to read you a bedtime story? Cause I will.

FIONA

I said GOOD NIGHT!

(FIONA exits. A beat.)

DONKEY

She seems nice. You want me to read you a bedtime story?

SHREK

Say goodnight, Donkey.

DONKEY

Goodnight, Donkey.

X (#20 - SUNSET (1). SHREK and DONKEY fall asleep.) RED | LX 223 GO

FIONA VOICE OVER X (VIS: FIONA USA) OGRE LX GO

"By day, one way, by night another - this shall be the norm,
until you find true love's first kiss and then take love's true form."

SBY | BEN

END OF ACT 1

ACT 2

SCENE NINE

BEN BLUE

X (Sunrise, the next day. FIONA enters.) LX 231 + SPOTS GO

(#21 - MORNING PERSON begins.)

SHREK
It's on my to-do list. Come on!

X ~~(FIONA climbs down from the tower. DONKEY runs across the stage.)~~ (V.S. X.U.S.) LX 205 GO

SHREK
Donkey!

DONKEY
Shrek!

X (DRAGON enters chasing DONKEY.) LX 207 WHITE GO

FIONA
Dragon!

ALL
Run!!

X (#19 - THIS IS HOW A DREAM COMES TRUE.) LX 211 + SPOTS GO

THIS IS HOW A DREAM COMES TRUE

SOUND

(DRAGON chases DONKEY offstage, SHREK follows. FIONA crosses downstage to sing.)

DRAGON:
(Roar!) X



FIONA:
(while the battle is in progress)



This is how I pic-tured it, More or less, I

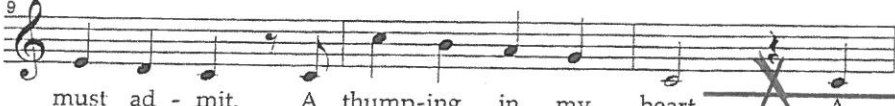

must ad - mit. A thump-ing in my heart. X A

SOUND LX 212 GO

(DONKEY followed by SHREK crosses, being chased by the DRAGON.)

Rit. A Tempo

12
life a - bout to start... I knew this day would

SBY SOUND

15
come, and you would find your way. At

SOUND LX 213 GO

SBY SOUND

A Tempo Faster!

18
last, my dream comes true. I knew, I knew, I

SHREK: (addressing FIONA)
You know, we could really use
a little help here, Princess. Really?
Nothing? Best. Day. Ever!

21
knew...

SOUND LX 214 GO

Stately, victorious
FIONA:

24
It would be to - day

NO SOUND

BLUE LX 215 SPOTS GO OUT

In 4
27

X (ON BUTTON) LX 218 GO

SHREK

To get my swamp back.

FARQUAAD

Yes, and you've nearly accomplished it! All you need to do is rescue Princess Fiona from the dragon, bring her to me to marry, and I'll hand over the deed to your swamp.

SBY LX 163

THELONIOUS

The dossier on her royal highness

(#10 - WHAT'S UP, DULOC (REPRISE) begins.)

WHAT'S UP, DULOC? (REPRISE)

(GUARD hands the confused SHREK a file.)

FARQUAAD: My people, I will make this Princess Fiona my queen, and Duloc will finally have the perfect king!

LX 163 G0

4

5 ALL:

Things are look - ing up! Things are look - ing

ON THE RAILS SBY: CUE 8 ON VERBAL FROM KAT

8 FARQUAAD:

up! Things are look - ing up here in

ON THE DECK: SBY MAIN CLOSED ON PURPLE

11 ALL:

Du - loc. Here in Du - loc.

SBY SPOTSOVT SBY LX 165-170

Rall. Poco A Poco

14 FARQUAAD:

And no one's gon - na bring me

LX 165 G0

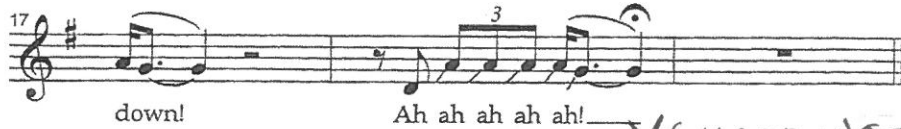

PURPLE
LX169GO

(FARQUAAD and the DULOCIANS have all vanished.
SHREK and DONKEY find themselves back outside the
gates of Duloc.)

X (VIS: SHREK + DONKEY, XDS)

LX171GO

SHREK

Well that was odd.

DONKEY

Not as odd as you agreeing to go on this quest! What do you know about rescuing a princess?!

SHREK

I've read the stories.

DONKEY

And I've read the sports page – that don't make me a hockey player!

ON THE DECK: SBY-
MAIN OPEN ON PURPLE

SHREK

(reading file)

It says she's been locked in the tower since she was seven.

DONKEY

Aw, that's sad. Only seven years old.

SBY: SPOTS 1+2 ON FIONA
USC IN PINK/FROST
+ LX 172 + 173

SHREK

(to the audience)

X Sounds like a cue for a flashback, doesn't it?

LX172GO

DONKEY

(confused)

Who are you talking to?

SHREK

No one. Let's go rescue the princess.

X (ONCE KAT GIVES DECK CLEAR) LX172.5 + PURPLE GO

(#11 – FIONA TOWER MOVE begins. They exit and we transition to (#12 – I KNOW IT'S TODAY.)

X (ON MUSIC) LX173 + SPOTS GO

RAIL/SCENIC:

PROPS:
Sign DSR, JRw/pinocchio suitcase,
Pigs suitcases, NB broom

OTHER:

⊕ = plant

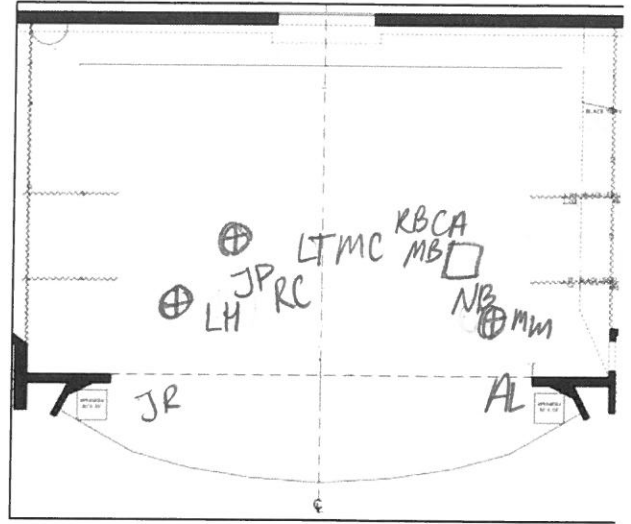



1. JR x DSR
3. JR x DSR

3. JR x DSC

4. JR x DSR

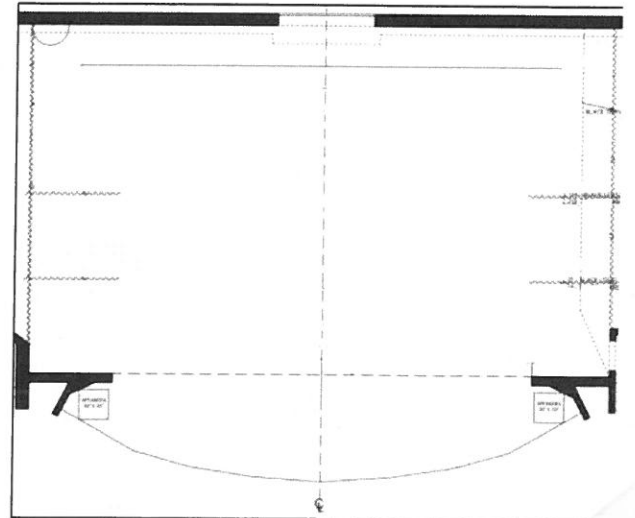
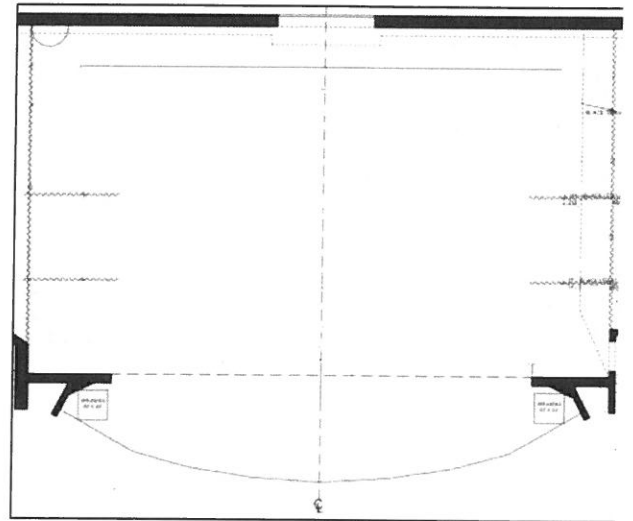
5. JR & Son suitcase



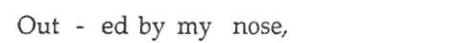

13  know,  Out - ed by my nose,

15  that's just how it goes—  for poor Pi-

17  no - cchi - o.—  Sto - ry of my life.

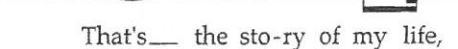
19  Al - ways doomed to fail.—  Cheat-ed by a fox.

21  Swal-lowed by a whale.  That's— the sto-ry of my life,

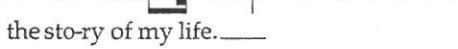
23  Oh yeah.  That's the sto-ry of my life.—

1. CAPTAIN OF THE GUARDS: Three Bears, take your spot over there by that sign. (The THREE BEARS try to find it.) No, that's too far. (again) Too close. (again) Ahh, just right. Wicked Witch!

26 

RAIL/SCENIC:

PROPS:

OTHER:

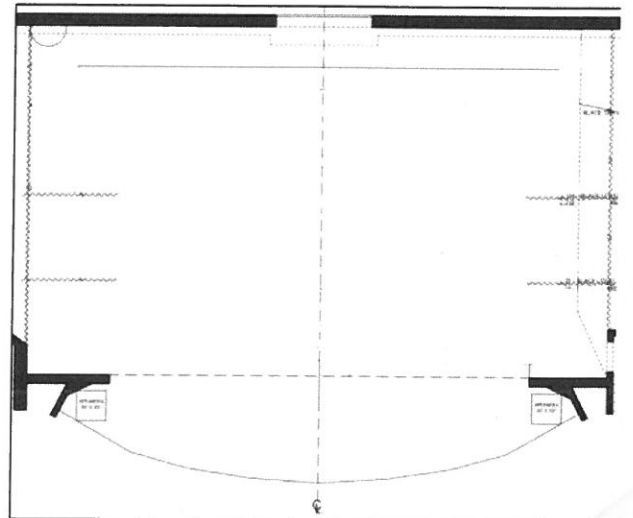
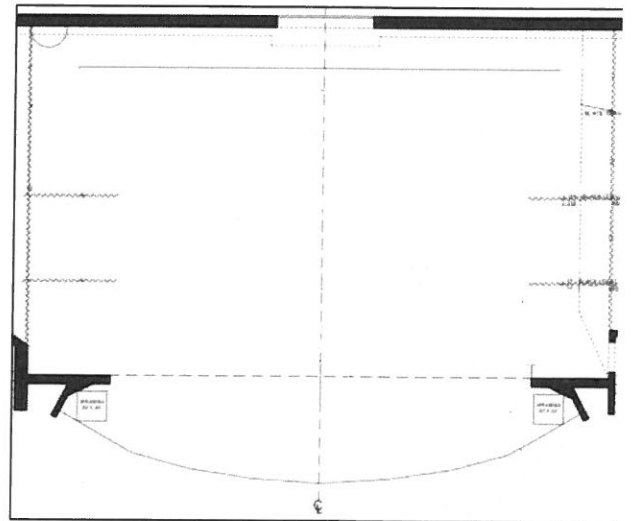
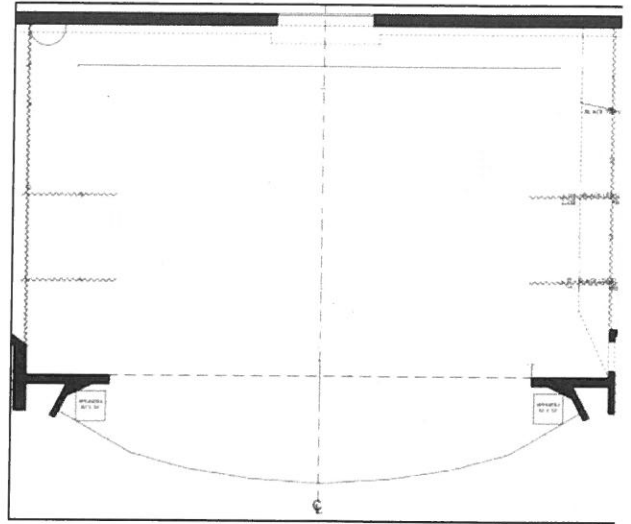

- ① MC, LT x DSR
- ② MC, LT x USR
- ③ MC, LT x → original position
- ④ AL x CS

WICKED WITCH:

CAPTAIN OF THE GUARDS:
Peter Pan!

31

Strife is ne - ver - end - ing,

PETER PAN:

CAPTAIN OF THE GUARDS:
Ugly Duckling!
UGLY DUCKLING:

33

Ban - ished from the town. They

WICKED WITCH:

① CAPTAIN OF THE GUARDS:
Three Pigs!

35

dragged me from the pond. They broke my mag - ic wand.

3 PIGS:

37

Zey blew our con - dos down.

WICKED WITCH:

CAPTAIN OF THE GUARDS:
Mama Bear!

② 40

Life is but a witch - hunt.

MAMA BEAR:

PETER P.
MAD HATTER:

42

Ma-ma's in the mud, Ma-ma's in dis - tress. They

3 PIGS:

BIG BAD WOLF:

44

ri-di-culed my hat. Zey said zat vee vere fat. They

RAIL/SCENIC:

PROPS:

OTHER:

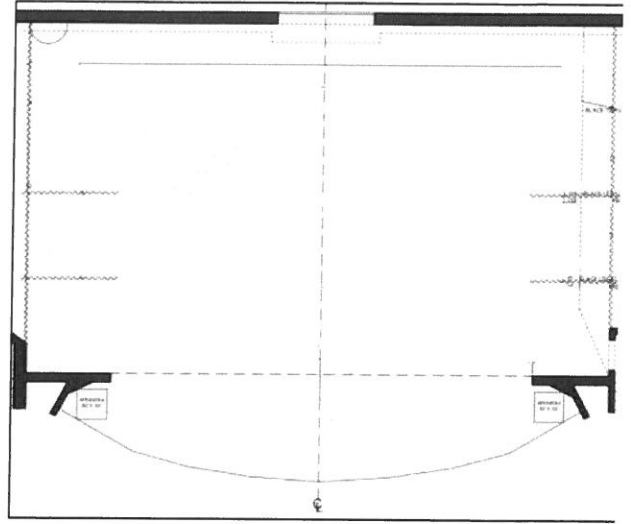

① AL x SR "Scared by pigs"

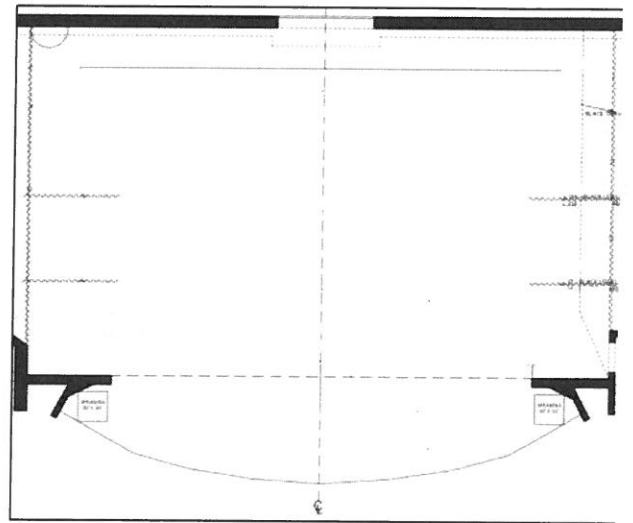

② JR S[↑] x CS

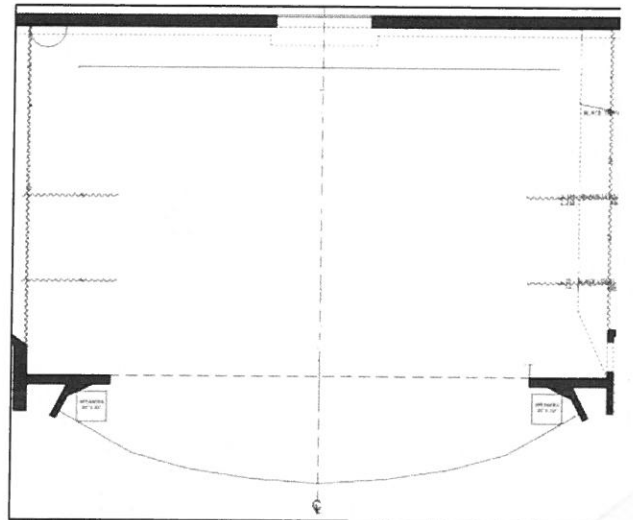

46 lab - eled me a fash - ion mess be -

47 cause I wore a gran-ny dress!

CAPTAIN OF THE GUARDS:
Park it there, Wolf!

49 **ALL:** Sto - ry of my life. Boot - ed from the ball. — The

51 **PETER PAN:** par - ty's off the hook I flew in-to a wall. —

CAPTAIN OF THE GUARDS:
And remember, if we find you back
in the kingdom, you will be executed. **2**

53 **ALL:** That's the sto-ry of my life. **3**

3 **ALL:** That's the sto-ry of my life. —

RAIL/SCENIC:

PROPS:

OTHER:

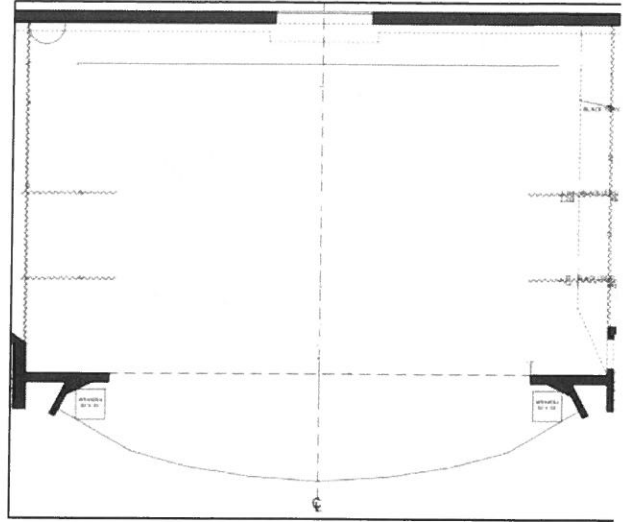

① X → FMT

② AL ex SR1

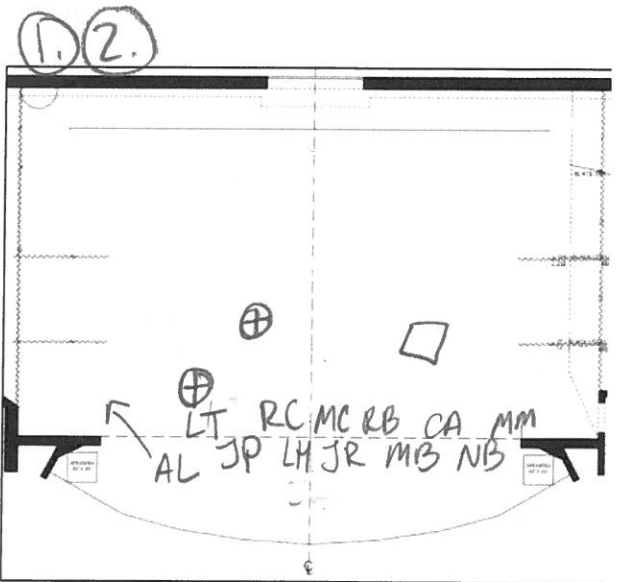

③ X → FMT

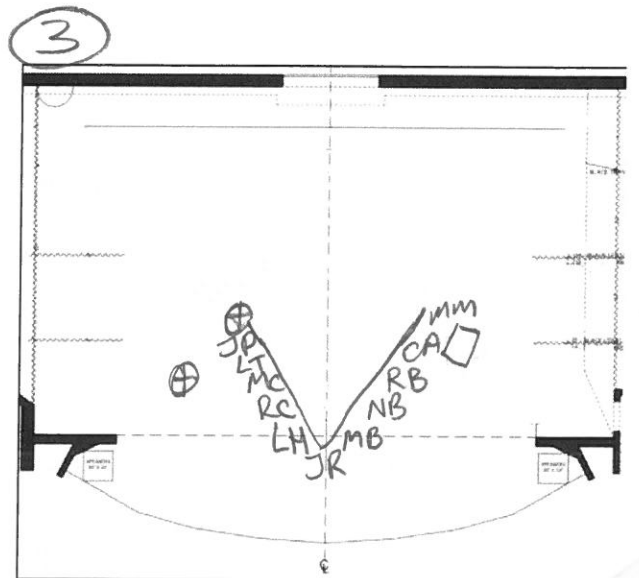

(ALL:)



59 I al-ways dreamed I'd get a hap - py end - ing.

① WICKED WITCH:



61 And this right here?_ Not how it goes.

② ALL:



66 I al - ways dreamed I'd get an e - ver af - ter._



65 If this is it, it blows.____ It blows. It blows.____



68 Sto - ry of my life. Al - ways dou - ble crossed.

④



70 Al - ways in the woods. Al - ways get - ting lost.



72 Al - ways on the ropes. Al - ways up a creek.

RAIL/SCENIC:

PROPS:

OTHER:

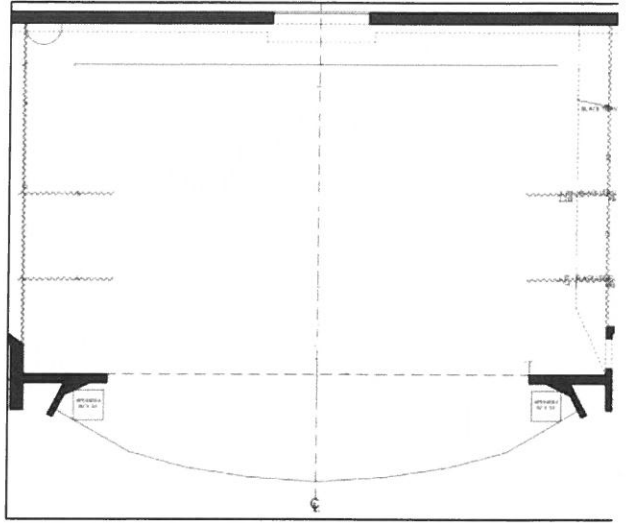

① all shake heads

② SR ↻ face CS; SL ↻ face CS

③ X → FMT

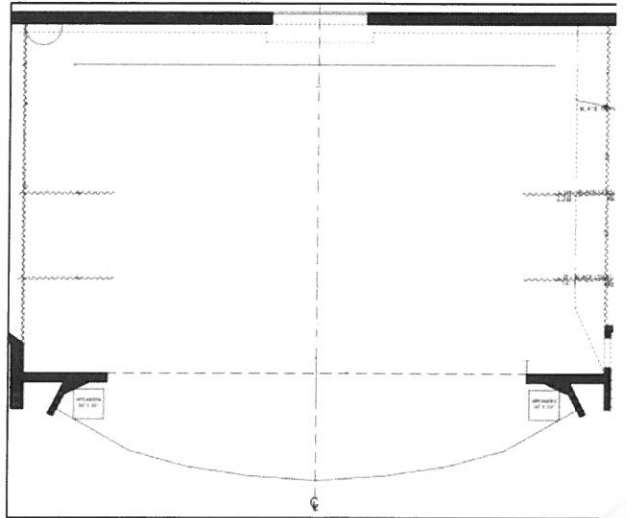
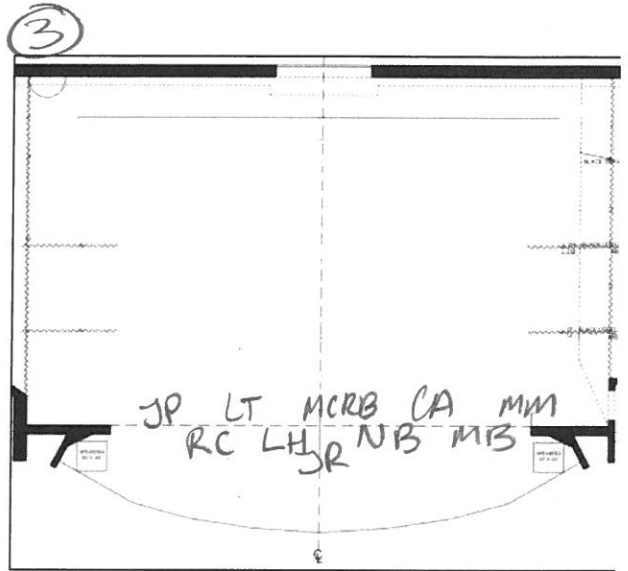

74 

Al-ways kicked a-round, And trea-ted like— a freak!

76 

That's the sto-ry of my life, Yes sir.—

78 

That's the sto-ry of my life, Oy vey!

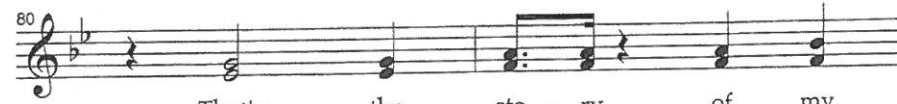
80 

That's the sto - ry of my

82 

life. _____

 (SHREK comes back from his errand and can't believe his eyes. He's confused and angry.)

SHREK

 What are you doing in my swamp?

PINOCCHIO

Well gosh, we were forced to come here.

SHREK

Forced? By who?

RB **FIG #2**

Lord Farquaad! He hooed and he poofed, and he signed an erection notice.

RAIL/SCENIC:

PROPS:

OTHER:

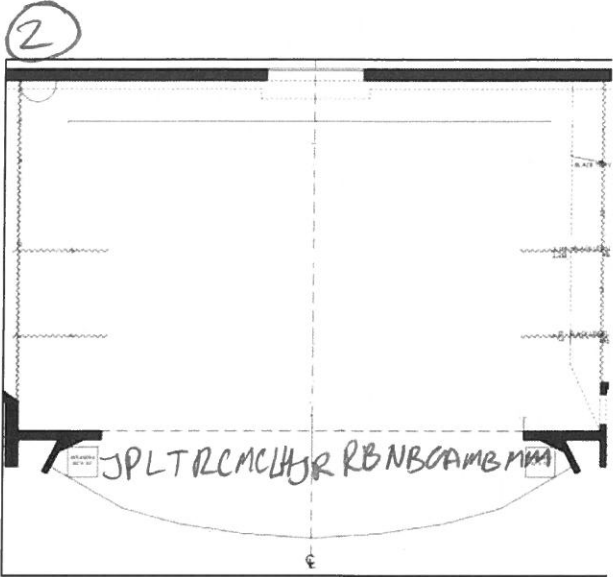

② in FMT

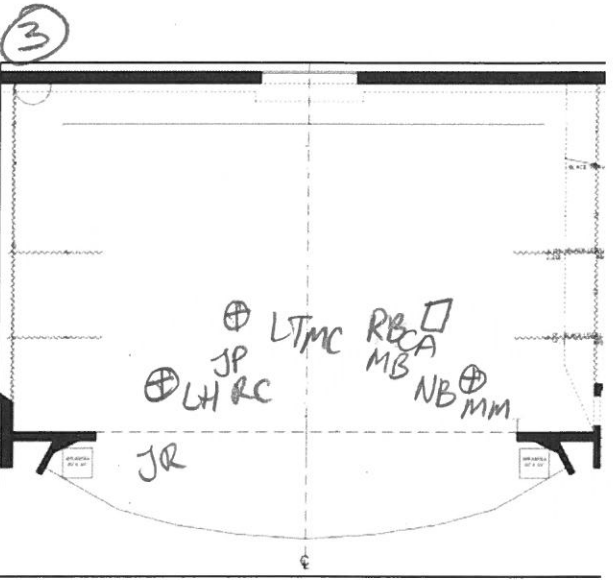

③ x → FMT

④ CW ext SL1

⑤ LT ext SRZ

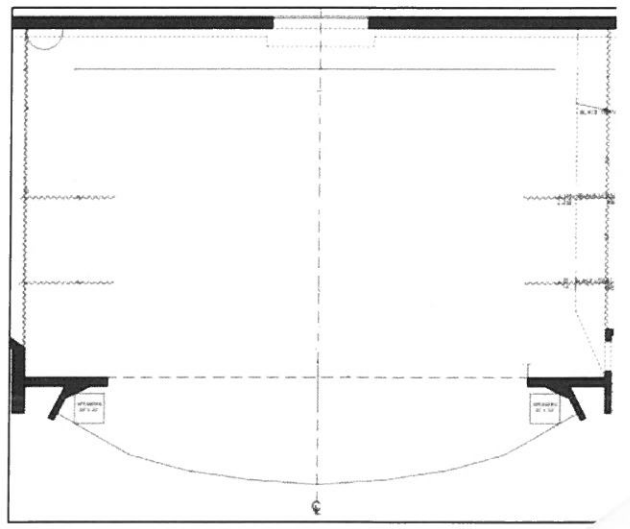

	Scene 1									Scene 2					Scene 3						
	#1 Prologue	#2 Pinktastic		#3 Just One More	#4 Temper Tantrum	#5 You Get Just What You Get	#6 Cupcake Dream	#7 When Dreams Come True		#8 WDCT Reprise, Bike Journey, Dr. Wink Transition		#9 Pinkititis		#10 Pinkititis Reprise		#11 I Got the Pink Blues		#12 Buzz Off/ #13 Buzz Off Playoff		#14 1-2-3	#11 When Dreams Come True Reprise #2
	Pg 1-3	Pg 3-6	Pg 6-8	Pg 8-10	Pg 10	Pg 10-11	Pg 11-12	Pg 12-13	Pg 13-15	Pg 15-16	Pg 17-1	Pg 18-19	Pg 19-20	Pg 20-2	Pg 22	Pg 23-24	Pg 25-27	Pg 27-31	Pg 31-32	Pg 32	Pg 33
Danny Adams (Mr. Pinkerton)	X		X	X			X	X	X	X	X	X	X	X	X	X			X	X	
Emily Bacino-Althaus (Alison)			X				X										X	X			
Mya Bryant (Mrs. Pinkerton)	X	X	X	X	X	X		X	X	X	X	X	X	X	X	X	X	X	X	X	
Christina Jordan (Pinkalicious)	X	X	X	X	X	X	X	X	X	X	X	X	X	X	X	X	X	X	X	X	X
Evan Hussey (Dr. Wink)							X				X	X	X	X	X			X			
Marc Pavan (Peter)	X	X	X	X			X	X	X	X	X	X	X	X	X	X		X	X	X	

	Scene 4			Scene 5			Scene 6			Scene 7				
		#16 The Power of Antioxidants		#18 Night Kitchen	#19 La La La	#20 Cupcake Dream		#21 Pinkalicious and Peter Ponder the Predicament	#22 Green Food/#23 Green Food Playoff		#24 Pink-A-Boo		#25 Finale	#26 Bows
	Pg 34	Pg 34-37	Pg 37-40	Pg 42	Pg 42	Pg 43-44	Pg 44-45	Pg 45-48	Pg 48-51	Pg 52-54	Pg 54	Pg 54-55	Pg 55-58	Pg 58
Danny Adams (Mr. Pinkerton)	X	X	X							X	X	X	X	X
Emily Bacino-Althaus (Alison)										X	X	X	X	X
Mya Bryant (Mrs. Pinkerton)	X	X	X							X	X	X	X	X
Christina Jordan (Pinkalicious)	X	X	X	X	X	X	X	X	X	X	X	X	X	X
Evan Hussey (Dr. Wink)														X
Marc Pavan (Peter)	X	X	X				X	X	X		X	X	X	X

MAMMA MIA!

ENT/EXIT PLOT

ACT ONE

		Prologue- The Beach			Scene 1- The Beach				Scene 2- Courtyard						Scene 3- Courtyard														
Song		1. Overture	2. I Have a Dream	3. Honey, Honey				4. Money, Money, Money		4a. Scene Change		5. Thank You For The Music				6. Mamma Mia (p1)			6. Mamma Mia (p2)										
Pg		1	2	3	4	5	6	7	8	9	10	11	12	13	14	15	16	17	18	19	20	21	22	23	23	24	25	26	
Principals	Danny Adams (Sky)									RRO						R1													
	Emily Bacino-Althaus (Sophie)	L1	L1	L1					L1	L1						AR	AR/LES		LES				AR						
	Heather Beck* (Tanya)									LV						RES													
	Nick Carroll (Harry)																LV												AR
	Bonner Church (Rosie)									LV						RES													
	Colleen Johnson* (Donna)									RES						RES									RES				LES
	Christopher de Prophetis* (Sam)																LV												AR
	Tyler Sonkin (Bill)																LV												
Female Ensemble	Brittany Ambler (Ensemble)												AR			L1								LES/LES				L1/R1	
	Mya Bryant (Lisa)			LV					L1					AR		L1								RRO/RRO				L1/R1	
	Christina Jordan (Ali)			LV					L1				AR			L1								LRO/LRO				L1/R1	
	Maddie Keller (Ensemble)													L1		L1													
	Grace Lynch (Ensemble)												LES			LES								LES/LES					
	Emily Royer (Ensemble)													L1		L1													
Male Ensemble	Craig Franke (Ensemble)													LRO		L1													
	Evan Hussey (Ensemble)													LRO		L1								RES/RES					
	Christopher Michael (Ensemble)													LRO		L1													
	Marc Pavan (Pepper)												LRO/LES	R1		R1								RJ/RJ					
	Darren Velardez (Eddie)												LRO/LES	RV		R1								L1/L1					
	Nicholas Wilson (Ensemble)													R1		R1													

MAMMA MIA!

ENT/EXIT PLOT

ACT ONE

		Scene 4- Donna's Room											Scene 5- The Beach			Scene 6- Courtyard						Scene 7- Jetty				Scene 8- Courtyard					
Song		7. Chiquitita						8. Dancing Queen	8a. Scene Change	9. Lay All your Love on Me			10. Super Trouper			11. Gimme, Gimme, Gimme			12. Name of the Game				13. Voulez Vous								
Pg		27	28	29	30	31	32	33	34	34	35		36	37	38	39	39	40	41	42	43	44	45	46	47	47	48	49	50	51	52
Principals	Danny Adams (Sky)											LV		R1															L1		L1
	Emily Bacino-Althaus (Sophie)											RRO											L1	LV							L1
	Heather Beck* (Tanya)	R								LRO						RES			RES												
	Nick Carroll (Harry)																			LV				R1							L1/L1
	Bonner Church (Rosie)	R								LRO						RES			RES												
	Colleen Johnson* (Donna)		LRO							LRO						RES			RES												
	Christopher de Prophetis* (Sam)																				LV			R1					AR		LRO
	Tyler Sonkin (Bill)																			LV		L1		LV			RV				
Female Ensemble	Brittany Ambler (Ensemble)														AR								AR					L1		L1	
	Mya Bryant (Lisa)														RRO								L1			L1/L1		L1		L1	
	Christina Jordan (Ali)														RRO								L1					L1		L1	
	Maddie Keller (Ensemble)														L1			R1	R1				R1					L1		L1	
	Grace Lynch (Ensemble)														R1				L1	L1			R1					L1		L1	
	Emily Royer (Ensemble)														LES								R1					L1		L1	
Male Ensemble	Craig Franke (Ensemble)										R1/L1		L1	L1/L1	R1													L1		L1	
	Evan Hussey (Ensemble)												L1	L1/L1	R1													L1		L1	
	Christopher Michael (Ensemble)										R1/L1		L1	L1/L1	R1													L1		L1	
	Marc Pavan (Pepper)										LRO/LRO		L1	L1/L1	R1													L1		L1	
	Darren Velardez (Eddie)										RRO/AR		L1	L1/L1	R1													L1		L1	
	Nicholas Wilson (Ensemble)										LRO/L1		L1	L1/L1	R1													L1		L1	

MAMMA MIA!

ENTRANCE/EXIT PLOT KEY
KATY SULLIVAN, ASM

ABBREVIATION	LOCATION
LV	Stage Left Vom to House
LRO	Stage Left Romeo Door
LJ	Stage Left Juliet
L1	Stage Left Wing
LES	Stage Left Escape Stairs Off Platform
AR	Center Stage Archway (via SR)
RV	Stage Right Vom to House
RRO	Stage Right Romeo Door
RJ	Stage Right Juliet
RES	Stage Right Escape Stairs Off Platform
	Quick Change

SHREK JR.

Maine State Music Theatre

Rehearsal Report #12

Date: Tuesday, July 20th, 2021

Director: Betsy Puelle

Stage Manager: Katy Sullivan

Today we finessed the timing of puppets in Travel Song, the movement of the two Fionas in I Know It's Today, and added props into Freak Flag. Then we ran the show with notes.

• ***Please see the Entrance Exit Plot attached!***

Scenery/Paints:

1. We would like the side panels of the Travel Song Flat to be attached with Hinges instead of clamps. When the flat is in its "closed" position, we would like to have it pinned securely closed. The actors will set the Flat on spike, remove the pins, and pivot the side panels to the open position. All this is done out of the audience's sight (upstage of the main curtain), but it does need to setup rather quickly (less than a minute).
2. On the upstage side of the Travel Flat (in its closed position) we would like to devise a way to store the puppets in such a way that the flat and the props can all travel onstage compactly. (scenery/props)
3. The Travel Flat will be pushed partially onstage through R2 at the top of scene 9. Anything that can be done to the bottom of the Travel Flat for a smoother push would be appreciated (felt was suggested).
4. The House Main will track open and closed throughout Shrek. It will NOT fly during Shrek. House Main will be preset in the closed position at the top of the show.
5. The Dragon will have four different trim heights (Out, High, Mid, and Low). Specific flight pattern for the dragon sequences have yet to be determined.
6. Confirming that Shrek will utilize one flown arch, and Beauty and the Beast will utilize all three. The three Beauty & the Beast arches will be flown on lineset 15, as designed. We are interested in moving the single arch for Shrek to lineset 19, but are also willing to consider lineset 20 if proximity to the electric is too close. The Shrek arch will split center.
7. Confirming that the upstage Trees will be dead-hung between L/S 23 [Black Traveler] and L/S 24 [Sun]. The lower portion of the trees will be upstage of the groundrow.

Props:

1. Can Puss in Boots' right arm be rigged so that the puppeteer can make him wave (up and down) during Travel Song?
2. On the upstage side of the Travel Flat (in its closed position) we would like to devise a way to store the puppets in such a way that the flat and the props can all travel onstage compactly. See Scenery Note #1 for more information on what we have in mind for the flat itself. (scenery/props)

Electrics/Lighting/ Projections:

1. Confirming that Shrek will utilize one flown arch, and Beauty and the Beast will utilize all three. The three Beauty & the Beast arches will be flown on lineset 15, as designed. We are interested in moving the single arch for Shrek to lineset 19, but are also willing to consider lineset 20 if proximity to the electric is too close. The Shrek arch will split center.

Music/Sound:

1. We would like to add a “magical” sound effect on page 17, when the Wicked Witch’s broom stands on its own and she says “I’m gonna spell it out for ya.” Approximately three to five seconds in length.

Costumes/Wardrobe/Wigs:

1. What are the mechanics of the Big Bad Wolf’s transformation from Granny Dress to Sparkly Dress in Scene 11? We are hoping that the actor will be able to pull the granny dress off to reveal the sparkly dress one smooth motion (hopefully during a switch-leap).
2. What is the current ETA for a costume plot?
3. Please see attached for our most up-to-date entrance/exit plot.
4. Farquaad’s miniature legs no longer need to detach.
5. Will the Rat Dancers and Blind Mice have noses as part of their costumes?
6. The Pinocchio nose will need to be affixed tightly to John R.’s face so it will stay in place when he tumbles at the end of Freak Flag.

Company Management:

1. Nothing new today, thanks!

Facilities:

1. Nothing new today, thanks!

Production Manager:

- 1.

Script:

1. Nothing new today, thanks!

Health:

1. All Good.

SM/Notes:

1. Nothing new today, thanks!